

INCEPTOR® NANO5

Technical Specification

Product Code: OV5400CH5WD

Description: 4.8W LED Fixed Dimmable Downlight - IP65 - 2700K - Chrome

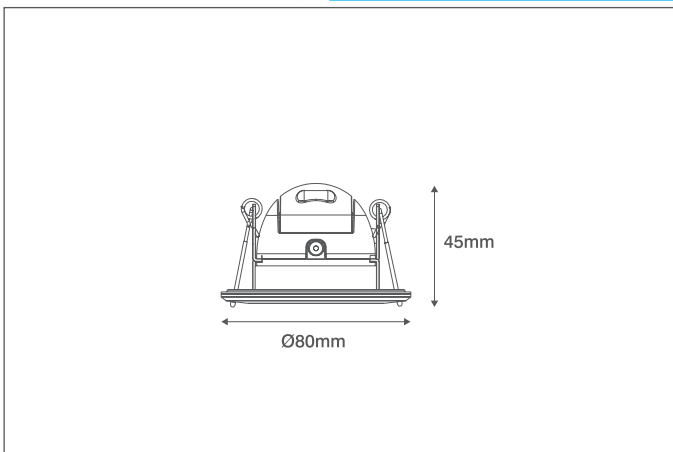

General Information

Dimensions	80mm Diameter x 45mm (D)
Materials	Bezel: Aluminium (Plated or Powdercoated)
	Rear Frame: Steel
	Rear Housing: ABS
	Lens: Polycarbonate
Finish	Polished Chrome
Product Weight	0.24Kg
Cutout	60mm Diameter
Dimmable	Yes
Ingress Protection	IP65
Airflow (BS 5250)	0.05m ³ /h m ² at a pressure difference of 2 Pa
Ceiling Thickness	40mm Max.
UK Patent No.	GB2571974B
Warranty	3 Years

Supply & Power

Input Voltage & Frequency	220-240V~ 50Hz
Electrical Safety	Class I
Circuit Wattage	4.8W
Input Current	30mA
Inrush Current	1.0A (15μs)
Power Factor	0.8
Ambient Temperature (Ta)	-15°C - +40°C
Critical Temperature	+80°C
LED Driver	Integrated
Prewired Flow™ Connector	Yes (3 Pole CT100-F Screw Terminals)

Luminaire Output

Colour Temperature	2700K
CRI	>80
Typical Luminous Flux	400lm
Efficacy	71lm/W
Beam Angle	40°
LED Lifetime (L70)	25,000 Hours

Accessories

OVISC1020	Insulation Support Bracket
OVEMCG2305M3	3 Hour Universal Emergency Pack with prewired Flow™ Connectors
OVSP4120CH	130mm Diameter Converter Plate - Chrome
OVEMCG2305M3	3 Hour Universal Emergency Pack with prewired Flow™ Connectors

Additional Approvals

Fire Rating	30 Minutes: 'I' Joists, Metal Web and Solid Timber Joists
	60 Minutes: 'I' Joists, Metal Web and Solid Timber Joists
	90 Minutes: Solid Timber Joists
Acoustic Rating	0dB (zero impact on sound insulation)
Air Flow™	BS 5250: 2011 compliant

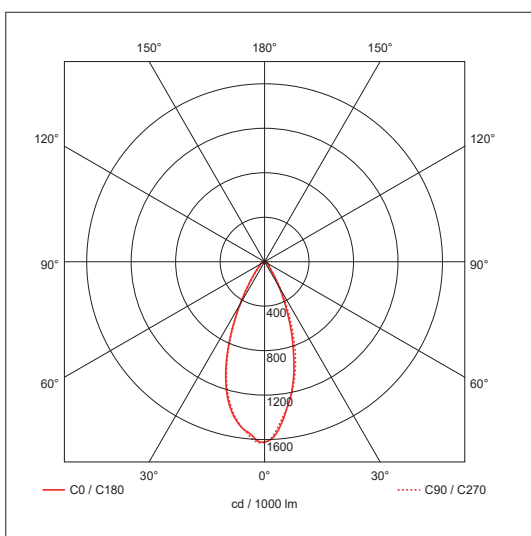

Ovia Limited, Scolmore House, Mariner, Lichfield Road Industrial Estate, Tamworth, Staffordshire, B79 7UL United Kingdom

T: +44 (0)1827 300640

E: sales@oviaUK.com | W: oviaUK.com